



MetacoN Next
fire door solutions

Short guide

FS Control 400V

MetacoN-Next ref. 53200

Hold-open system for 400V drives

With digital limit switch or cam limit switch

Software version 6V72

21-07- 2025

For the complete manual use this QR code



Model name : MO710DZFSA.MET

Version basic board : MO710DZCH-V6

Version alarm board : ZANBF V2

Table of contents

| | | |
|-----------|--|-----------|
| 1 | Language selection & security measures | 3 |
| 1.1 | Display language setting | 3 |
| 1.2 | Attached load | 3 |
| 1.3 | Power supply connection | 3 |
| 1.4 | Maximum permitted cable lengths | 3 |
| 1.5 | Transport and storage | 3 |
| 1.6 | Maintenance work | 3 |
| 1.7 | Removal | 3 |
| 1.8 | Declaration of conformity | 3 |
| 2 | Overview of connections | 4 |
| 2.1 | Terminal connections MO710DZCH V6 | 4 |
| 2.2 | Terminal connections ZANBF V2 | 4 |
| 3 | Connecting motor cable | 5 |
| 3.1 | Motor cable with digital limit switches | 5 |
| 3.2 | Motor cable with cam limit switches | 5 |
| 4 | Adjusting limit switches and learning motor running time | 5 |
| 4.1 | Adjusting digital limit switches | 5 |
| 5 | Adjusting mechanical limit switches | 6 |
| 6 | Set operating mode "go to the operating mode menu item in the configuration menu" | 7 |
| 6.1 | Operating mode selection 1 (factory default) | 7 |
| 6.2 | Operating mode selection 2 | 7 |
| 6.3 | Operating mode selection 3 | 7 |
| 6.4 | Operating mode selection 4 | 7 |
| 6.5 | Operating mode selection 5 | 7 |
| 6.6 | Operating mode selection 6 (DIBt) | 7 |
| 6.7 | Operating mode selection 7 (DIBt) | 7 |
| 6.8 | Operating mode selection 8 (DIBt) | 7 |
| 6.9 | Operating mode selection 9 (DIBt) | 7 |
| 7 | Connecting roll-off protection | 8 |
| 7.1 | Connecting the roll-off guard | 8 |
| 8 | Connecting cable break protection | 8 |
| 8.1 | Cable breakage protection (with resistance monitoring) | 8 |
| 9 | Connecting fire detectors | 8 |
| 9.1 | Fire detector with 2-wire technology | 8 |
| 10 | Optional connection options | 9 |
| 10.1 | Light strip LIGI 07 OSE mounted in day | 9 |
| 10.2 | Light strip LIGI 01 OSE mounted in the day | 9 |
| 10.3 | Light strip LIGI 01 OSE mounted on the day | 10 |
| 10.4 | Key switch | 10 |
| 10.5 | Pull-rope switch | 10 |
| 11 | Safety circuit | 10 |
| 11.1 | Bridging the safety system | 10 |
| 11.2 | Emergency operation | 10 |
| 11.3 | Emergency mode | 11 |
| 12 | Error message table | 11 |
| 13 | Configuration menu | 12 |
| 13.1 | ZS7 Display default PIN = 2.8.4.1 | 12 |
| 14 | Retention system | 13 |
| 14.1 | ZANBF V2 | 13 |
| 15 | Guidelines and standards | 14 |
| 15.1 | Machinery directives | 14 |
| 15.2 | Standards | 14 |
| 16 | Mechanical and electrical data | 15 |
| 16.1 | Connecting motor cable with digital limit switches | 16 |

1 Language selection & security measures

1.1 Display language setting

If you want to change the language to e.g. Dutch of your display, through the menu item **[OPTIONS]** & **[LANGUAGE]** via the display, you can convert it to your choice. The required access PIN is 2841.

All instructions in this manual must be followed by the user. In principle, only qualified electricians may work on electrical installations. They must be familiar with the relevant regulations, recognise possible sources of danger and be able to take appropriate safety measures.

The operating safety of the control unit is only guaranteed if it is used as intended.

When installing, commissioning, maintaining and testing the control unit, the applicable safety and accident prevention regulations must be observed.

1.2 Attached load

Maximum load of control 400Vac, 50Hz, three phase, max 4000W.

1.3 Power supply connection

Via fixed wiring and main switch on site or flexible mains connection cable with CEE plug. If the mains cable is damaged, it must be replaced immediately with a suitable mains cable by a qualified electrician.

1.4 Maximum permitted cable lengths

A maximum cable length of 30 metres is allowed for the inputs of the control unit. A maximum cable length of 10 metres is allowed for the outputs.

1.5 Transport and storage

The device must not be dropped or exposed to other external mechanical influences. Liquids must not penetrate the housing.

1.6 Maintenance work

The control unit is maintenance-free.

1.7 Removal



In accordance with EU directives, electronic devices and batteries must not be disposed of with household waste. Use the return and collection systems available in your country to return these devices.

1.8 Declaration of conformity



We hereby declare that this device complies with the basic requirements and relevant regulations of Directive 2014/53/EU and may be used without registration in all EU countries and Switzerland. The declaration of conformity can be found on the internet at

www.tedsen.com/?url=konformitatserklarungen

MetacoN-Next display PIN code = 2.8.4.1

2 Overview of connections

2.1 Terminal connections MO710DZCH V6

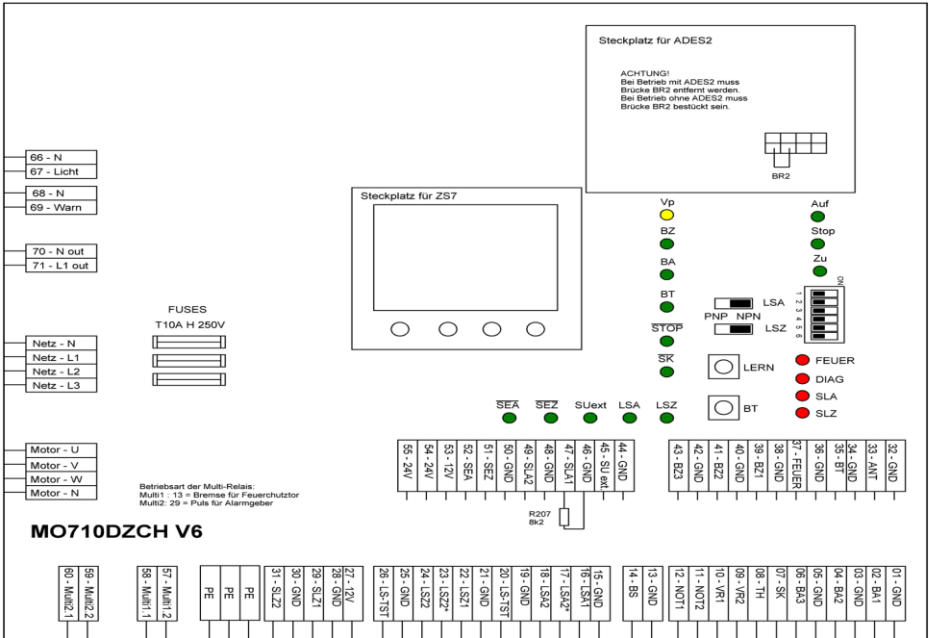

2.2 Terminal connections ZANBF V2

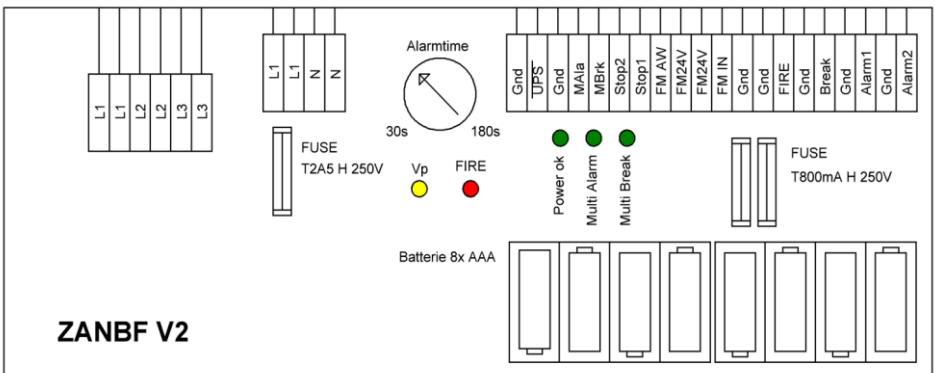

3 Connecting motor cable

3.1 Motor cable with digital limit switches

Follow the instructions of the wiring diagram see appendix drawing number ZSP 00359 02 page 3 of 4

See also page 16

3.2 Motor cable with cam limit switches

Follow the instructions of the wiring diagram see appendix drawing number ZSP 00359 02 page 4 of 4

4 Adjusting limit switches and learning motor running time

4.1 Adjusting digital limit switches

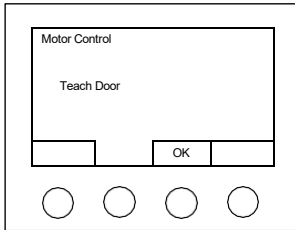

Go via the display of the FS Control 400V
To the learning programme **[Teach Door]**
press **[OK]**.

Start the learning programme

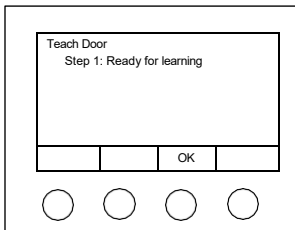

Press **[OK]** again at step 1: ready for learning, the learning programme starts and stops at step 4



Note ! do not press **[OK]** yet
the limit switches are not yet learned.

If you do accidentally press **[OK]**, the learning programme jumps back to Step 1 out of safety.

The safety circuit (SK-IN SK-OUT) is not yet closed the green **[STOP]** LED on the base board is still off.

Now put the ADES2 in learning mode, press learning key **[LERN]** for more than 3 sec.

in this learning mode the safety circuit (SK-IN SK-OUT) is closed, the green LED now flashes on the ADES2, this means that the end position open can be learned, green **[STOP]** LED on the base board now lights the safety circuit is now closed and the learning programme can be run.

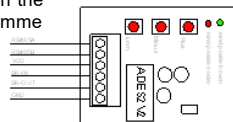

Now adjust the limit switches

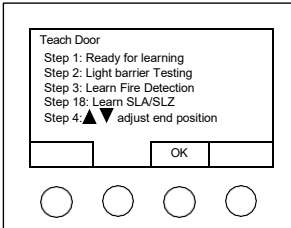

Now go up in Deadman with the arrow key and open it up to its end position. At correct end position, release the arrow key, try to reach the end position with short small pulses as little as possible, rather go back a good bit if necessary and start again.

Record the end positions in the ADES2

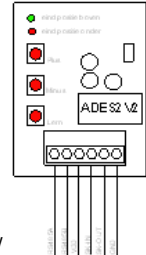

At the correct end position open, briefly press the **[LERN]** button of the ADES2, the green LED stops flashing. The green LED stays on continuously and the SEA LED on the MO710DZ PCB goes off.

The red LED now starts flashing, now find the correct end position close, release the arrow key and press the **[LERN]** key of the ADES2, the red LED stops flashing and lights up continuously. The SEZ LED on the MO710DZ PCB goes off.

Note: If you have already connected the light sensor, first open the fire screen completely using the arrow key and then press OK. The SLZ closing edge status message for the light screen will then be cancelled.

Now continue with the learning programme

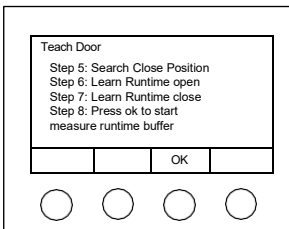

To learn the motor running time via the display on the MO710DZ, now press the **[OK]** button in the display to start the motor running time programme, the controller first searches the position close, runs open and then close again. During this procedure, a compensation calculation is also performed, which calculates a correction of the overrun end position during the fast running of the motor.

Continue to follow the instructions on the display of the FS Control 400V to exit the learning programme.

If everything is learned correctly, the ADES2 and the MO710DZ gives the following status.

The green LED on the ADES2 lights up at the end position open and the green LED SEA goes out on the MO710DZ

The red LED on the ADES2 lights up at end position closed and the green SEZ LED goes out on the MO710DZ

5 Adjusting mechanical limit switches

To adjust mechanical limit switch, you need to remove the ADES2 PCB, you can simply pull it up from the connection connector. A bridge is included with the motor cable for the cam limit switch version, it must be inserted into the ADES2 connection connector.

To adjust the limit switches, follow instructions from the relevant motor and go through the learning programme via the FS Control 400V display.



6 Set operating mode "go to the operating mode menu item in the configuration menu"

6.1 Operating mode selection 1 (factory default)

The control remains operable during a fire alarm, the motor is operated in both running directions, the brake is always engaged with SEZ, the control is automatically ready for operation after switching on the mains supply.

6.2 Operating mode selection 2

The control remains operable during a fire alarm, the motor is operated in both running directions, in case of fire it closes by gravity, the brake is always engaged with SEZ, the control is automatically ready for operation after switching on the mains supply.

6.3 Operating mode selection 3

The control remains operable in case of a fire alarm, the motor is used in both running directions, in case of fire it closes by gravity, the brake is not engaged with SEZ in case of fire, the control is automatically ready for operation after switching on the mains supply.

6.4 Operating mode selection 4

The control remains operable during a fire alarm and normal operation it closes by gravity, the brake is always engaged with SEZ, the control is automatically ready for operation after switching on the mains supply.

6.5 Operating mode selection 5

The control remains operable in case of a fire alarm and normal operation it closes by gravity, the brake is not activated with SEZ in case of fire, the control is automatically ready for operation after switching on the mains supply.

6.6 Operating mode selection 6 (DIBt)

The control is not operable during a fire alarm, the motor is used in both running directions, in case of fire it closes by gravity, the brake is not engaged with SEZ, the control is operable only after a manual reset after switching on the mains supply.

6.7 Operating mode selection 7 (DIBt)

The control is not operable during a fire alarm, the motor is used in both running directions, in case of fire it closes by gravity, the brake is not engaged by SEZ, the control is automatically ready for operation in the

end position fully open and at any other position only after a manual reset it is ready for operation again after switching on the mains voltage.

6.8 Operating mode selection 8 (DIBt)

The control is not operable during a fire alarm and normal operation it closes by gravity, the brake is not activated with SEZ in case of fire, the control is operable only after a manual reset after switching on the mains supply.

6.9 Operating mode selection 9 (DIBt)

The control is not operable during a fire alarm and normal operation it closes by gravity, the brake is not engaged with SEZ in case of fire, the control is automatically operable in the end position fully open, at any other position only after a manual reset operable after switching on the mains supply.

7 Connecting roll-off protection

7.1 Connecting the roll-off guard

You need to connect the supplied roll-off protector to the following terminals on the MO710DZCH V6 PCB, remove the bridge and connect it to terminal **[11-NOT2]** and terminal **[12-NOT1]**, this is the stop function .

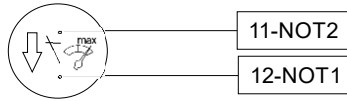

8 Connecting cable break protection

8.1 Cable breakage protection (with resistance monitoring)

You should connect the slack wire break protection contacts to the following terminals of the MO710DZCH V6 PCB, connect them to terminal **[46-GND]** and terminal **[47-SLA1]**, this will also control wire breakage etc. You can use the termination resistor 8k2 to terminate the loop with.

In the display, in the configuration menu, the SLA function is set to the correct function for (SLA=function 4).

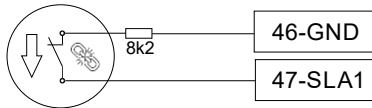

9 Connecting fire detectors

9.1 Fire detector with 2-wire technology

Take away the resistor 4k7 on the ZANBF V2 PCB connected to terminal **[FM-24V]** and terminal **[FM-IN]** and connect your fire detectors to this as shown in the diagram below. You can reuse the 4k7 resistor as a terminating resistor.

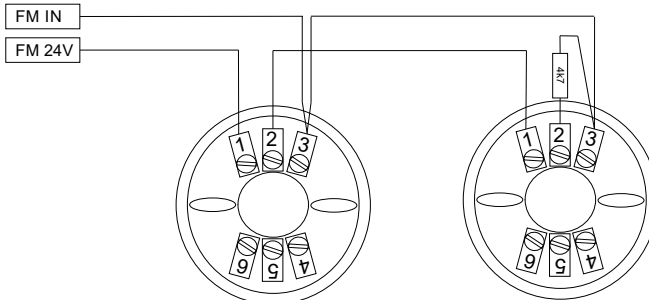

In the display, in the configuration menu, the SLZ function is set to the correct function for (SLZ=function 1).

If you are going to use fire detectors with 4-wire technology, refer to the detailed manual.

10.3 Light strip LIGI 01 OSE mounted on the day

Remove the 8k2 resistor and brown connecting wire from TX to terminal [28-GND] and white from TX to terminal [58-24V], connect brown RX connecting wire to terminal [58-24V] and white from RX to terminal [28-GND], connect green connecting wire from RX receiver to terminal [29-SLZ1] of MO710DZCH V6 PCB.

Connect the two yellow wires (synchronisation) together and set the function in the configuration menu of the SLZ closing side of 8k2 to OSE.

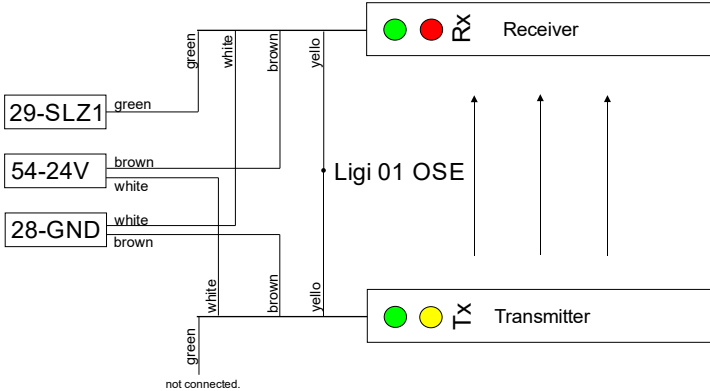

10.4 Key switch

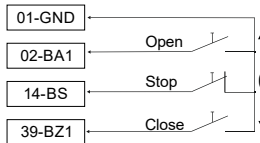

10.5 Pull-rope switch

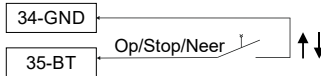

11 Safety circuit

11.1 Bridging the safety system

When used as a hold-open system and the door is closed by gravity, the normal limit switch may be overridden and a safety device interrupts the safety circuit. In this case, the control unit recognises a stop command and can no longer be operated.

By bridging the safety circuit, it is possible to open the door despite an interrupted safety circuit until the safety circuit is no longer interrupted or the open end position is reached. The safety functions SLA and LSA are monitored and cause the door to stop. To override the safety circuit, hold down the Stop button on the foil keypad and also press the Open button on the foil keypad. After an advance warning of 10 seconds, during which the warning light flashes rapidly, the door opens.

11.2 Emergency operation

If one of the safety devices LSA, LSZ, SLA or SLZ fails or is permanently signalled, only operation in emergency mode is possible.

11.3 Emergency mode

In emergency operation, the door can be moved with the OPEN or CLOSE buttons on the cover switch and/or the control inputs BA or BZ after a warning time of 10 seconds. The warning light flashes during the warning time.

Note! When emergency operation is activated, the door can be moved by opening or closing the cover switch and/or inputs BA and BZ, even if a safety device has failed. The control unit with the cover switch should therefore be installed so that the door is visible during operation.

12 Error message table

If the control unit recognises an error, the error is indicated by the status/diagnosis LED

| Error code | Error description |
|------------|---|
| 2 | An error was recognised when querying the DIP switches. Either you switched the DIP switches and did not press the [LERN] to save the change, or there is an error. |
| 3 | Both limit switches give a signal simultaneously. The limit switches should be checked. |
| 4 | The light barrier test for LSA failed. |
| 5 | The light barrier test for LSZ failed. |
| 6 | The test of the resistance evaluation SLA failed. |
| 7 | The test of SLZ resilience evaluation failed. |
| 8 | The runtime limit has stopped the door. Check the limit switches or learn a longer runtime reserve. |
| 9 | The voltage Uext 12V is not within the permissible range. Too much current is drawn. The control unit is locked. |
| 10 | The voltage Uext 24V is not within the permissible range. Too much current is drawn. The control unit is locked. |
| 11 | The data in the data memory is incorrect. The control unit must be re-learned. |
| 12 | Writing to the data memory of the control unit cannot take place. It is defective. The control unit must be repaired. |
| 13 | An error was detected in the redundant evaluation of the safety circuit. |
| 14 | An error has been detected in the power supply section. |
| 15 | Reserve. |
| 16 | Reserve. |
| 17 | Reserve. |
| 18 | Reserve. |
| 19 | Reserve. |
| 20 | SLA is configured as OSE and the OSE is faulty and delivers too high a frequency. |
| 21 | SLZ is configured as an OSE and the OSE is faulty and providing too high a frequency. |
| 22 | SLA is configured as a "safety circuit with resistance evaluation" or "fire detector" and the resistance value is outside the allowed range of 3k -5% to 8.2k +5%. |

13 Configuration menu

13.1 ZS7 Display default PIN = 2.8.4.1

The display shows

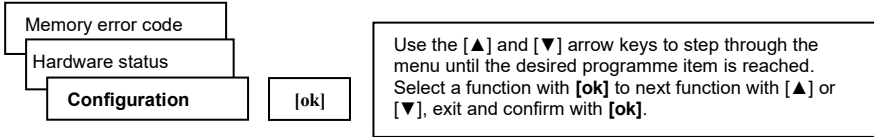

| Display shows: | Possible action: | Selection button | Info or action |
|--|---|---|--|
| Programme version | | | Info only |
| Serial number | | | Info only |
| Service counter | Shows total number of movements | | Info only |
| Operating hours counter | Displays total operating time | | Info only |
| Maintenance counter | Maintenance interval reset | [▲] or [▼]. | Delete yes/no |
| Maintenance interval | Maintenance interval setting | -1 or +1 | Number of settings |
| Holding time 1 | Open time setting (auto. closing) | -1 or +1 | 0-300 sec |
| Clearance time 1 | Setting evacuation time (after passage) | -1 or +1 | 0-300 sec. |
| Light time | Setting the lighting time (dip 5 off) | -1 or +1 | 0-300 sec. |
| Repeat fire command | Closing after opening on fire command | -1 or +1 | 0-300 sec. |
| Gebr. setting | | | |
| Save default setting | | | |
| Load default settings | | | |
| Signal for opening | 4 sec. prewarning before opening | [▲] or [▼]. | On or off |
| Fire alarm response | Motor control in case of fire alarm | [▲] or [▼]. | Open or close |
| Closes after pass. photocell | Quick close after passage activation | [▲] or [▼]. | Switching on or off |
| Signal for opening | Warning before opening | [▲] or [▼]. | flashing or lit continuously |
| Signal door moves | Warning during door movement | [▲] or [▼]. | Flashing or lit continuously |
| Signal on evacuation | Warning before the door closes | [▲] or [▼]. | flashing or lit continuously |
| Signal when door is closed | Warning when door is closed | [▲] or [▼]. | In or out |
| Signal at intermediate stop | Warning when door is in intermediate position | [▲] or [▼]. | In or out |
| Function closing edge bev. | Reaction on activation of closing edge rubber | [▲] or [▼]. | 1 = Stop and short on 2 = Stop and completely on. 3 = 1 sec. before end of stop otherwise entirely on. 4 = as 3 however 2 sec. 5 = as 3 however 4 sec. 6 = 1 sec. before end of stop by the way briefly on. 7 = as 6 however 2 sec. 8 = as 6, however, 4 sec. |
| Counter passage photocell | Only for barrier operation | [▲] or [▼]. | In or out |
| Vergr. overschr. runs. | Motor running time overrun monitoring | [▲] or [▼]. | In or out |
| Choose: Multifunction relay 1 Or | 1 | Service relay. Contact closes at set interval number of movements | |
| | 2 | Error message. Contact closes on fault message. | |
| | 3 | Hand-held transmitter control | Multi 1 pulse contact |
| | 4 | | Multi 1 on/off contact |
| | 5 | | Multi 2 pulse contact |
| | 6 | | Multi 2 on/off contact |

| | | | | |
|--|--|---|---|--|
| Multifunction relay 2 (At both Multicontacts can these options be chosen) | 7 | | Changeover contact Multi 1/2 | |
| | 8 | At control input ASU1 | Switches simultaneously with input ASU1 | |
| | 9 | At ASU2 input control | Not in use. | |
| | 10 | Contact is closed if the door is not closed. | | |
| | 11 | Message door open, potential-free contact closes when door is open. | | |
| | 12 | Message door closed, potential-free contact closes when door is closed. | | |
| | 13 | Working current brake. (Magnetic brake becomes active when voltage switches on) | | |
| | 14 | Quiescent brake. (Brake is activated when voltage is lost) | | |
| | 15 | Reserve | | |
| | 16 | Fault relay contact pulses with the fault indication according to table | | |
| | 17 | Fire alarm. N.O. contact for relaying a fire alarm. | | |
| | 18 | Low-speed relay (only for control with frequency inverter) | | |
| | 19 | Control of solenoid valve (Hydraulically operating door) | | |
| | 20 | Delayed opening with 2 units MO710AZ wing door | | |
| | 21 | Delayed closing 2 units MO710AZ wing door | | |
| | 22 | Obstacle during opening of wing door | | |
| | 23 | Pulse after switching on | | |
| | 24 | High-speed relay | | |
| | 25 | Door not open | | |
| 26 | Traffic control | | | |
| 27 | No fire alarm (contact breaks when a fire alarm is triggered) | | | |
| 28 | Closing with fire alarm (contact breaks on closing and a fire alarm) | | | |
| 29 | Pulse for start signal/acoustic signal | | | |
| 30 | Pulse with door opened (pulse duration approx. 1 sec.) | | | |
| Door closes after mains failure | Door reaction after power failure | [▲] or [▼]. | In or out | |
| Operating mode | Operating mode selection see page 15 | -1 or +1 | 9 choices | |
| Light relay functions | Choice of light relay or obstacle notification | [▲] or [▼]. | Light or Hindrance | |
| Emergency operation | Emergency operation after 10 sec. | [▲] or [▼]. | On or Off | |
| Opening LSA closing edge | Choice of 1 or max. 6 closing edge sensors | Single | Multiple light strips | |
| LSZ closing edge | Choice of 1 or max. 6 closing edge sensors | Single | Multiple light strips | |
| LSZ return function | Choice of light strip return functions | [▲] or [▼]. | LSZ backlash | |
| SLA closing edge system | Choice 8K2, 8K2 8K2, or OSE | [▲] or [▼]. | | |
| SLZ closing edge system | Choice 8K2, 8K2 8K2, or OSE | [▲] or [▼]. | | |
| Priority order | Choice traffic light priority order | -1 or +1 | 1=no 2=BTA 3=BTI | |

14 Retention system

14.1 ZANBF V2

The ZANBF V2 auxiliary board is a complement to the MO710DZCH V6 door control unit to create an enabling device for a hold-open system.

The ZANBF V2 performs the following functions:

- Monitoring of the three phases of the 400 V supply. In the event of a phase failure, the door control no longer works. In this case, the ZANBF V2 interrupts the safety circuit. The monitoring of the fire detector and the activation of the parking brake are then performed by the ZANBF V2.
- Power supply unit for fire alarms, brakes and audible and visual warning alarms. A parking brake can be operated with 24Vdc with a maximum of 1.0A. 24Vdc with a maximum of 700mA is available to power the fire detectors. 12Vdc with a maximum of 500mA is available for the acoustic and visual warning alarms.

- Evaluation of fire detectors using the current rise principle.
- Evaluation of fire detectors using the 4-wire principle.
- Battery for powering the acoustic and visual signal generator in case of power failure.

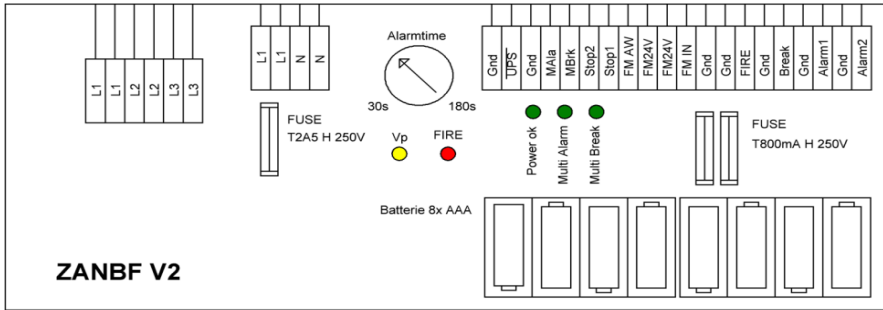

15 Guidelines and standards

15.1 Machinery directives

The FS Control 400V has been developed and built in accordance with the following guidelines and regulations as an uncompleted machine in accordance with Machinery Directive 2006/42/EC Annex II Part 1B:

| | | | |
|-----------|------------|---|--|
| DIRECTIVE | 2014/35/EU | : | Electrical equipment for use within certain voltage limits |
| DIRECTIVE | 2014/30/EU | : | Electromagnetic compatibility of equipment |
| DIRECTIVE | 2011/65/EU | : | ROHS, restricting the use of hazardous substances |

15.2 Standards

| | | |
|----------|-----------------------|---|
| EMC | EN 61000-6-2:2019-11 | Electromagnetic compatibility: immunity to interference for industrial applications. |
| | EN 61000-6-3:2022-06 | Electromagnetic compatibility: interference emission for residential, commercial and small businesses. |
| Security | EN60335-2-103:2016-05 | Safety of electrical appliances for domestic and similar use, special requirements for drives for gates, doors and windows. |
| | DIN EN 12453:2022-08 | Operating safety of power-operated doors - Requirements and test methods. |
| | EN ISO 13849-1:2016 | Safety of machinery - Safety-related parts of control systems (Cat. 2 / PLC emergency stop, evaluation 8k2, LS) |

16 Mechanical and electrical data

| | |
|--|---|
| Dimensions with housing | (L x W x H) = 430 mm x 320 mm x 170 mm |
| Current consumption of the control unit in active operation, without motor and external consumers at 400V 50Hz | <5W |
| Supply voltage | ~3 phases, 400Vac 10%, 50Hz |
| Power connector type | CEE-form 5 pin 16A |
| Storage temperature | -20 °C to +70 °C |
| Operating temperature | -10 °C to +50 °C |
| Relative humidity | max. 95% non-condensing |
| Engine | Three-phase motor 400Vac |
| Protection class | Without signal unit IP65 |
| Extra | 12Vdc 250mA and 24Vdc 500mA |
| | |
| Airborne noise emissions | < 70 dB(A) |
| Sealing resistance of the 8k2 safety edges | Resistance 8.2k 5% |
| | |
| Optical safety frame OSE | System Fraba OSE, Witt OSE or compatible. Low level < 1V, high level >3V, duty cycle 40% to 60%, frequency 800Hz to 1000Hz. Obstacle detection if the average frequency is <500Hz or >2000Hz in a 10 ms time window. |
| Voltage threshold for detection of an obstacle by the connected photocells | Operating mode "Photocell system with up to 6 photocells": 100mV |

16.1 Connecting motor cable with digital limit switches

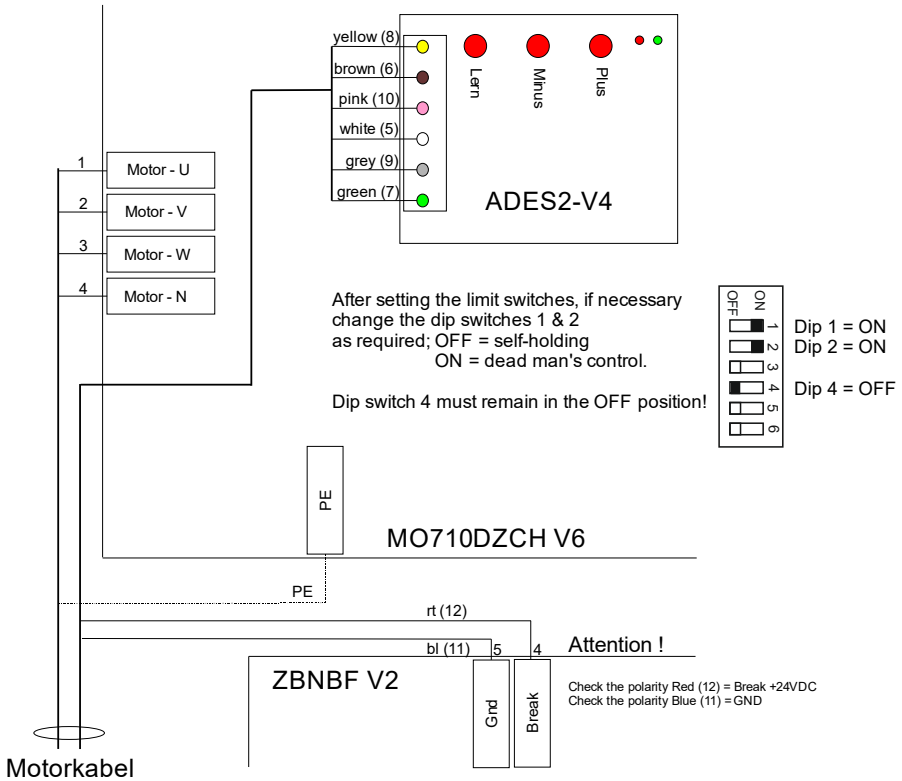

- Dip switch 1 ON= [Deadman] / OFF= [takeover] open
- Dip switch 2 ON= [Deadman] / OFF= [takeover] close
- Dip switch 3 ON=[automatic] closing after end of hold open and clearance time
- Dip switch 4 ON=[internal] / OFF=[external] limit switches (digital limit switches are external)
- Dip switch 5 ON=[light] output on when door opened / OFF=[light] switch-on/off time 180 sec on opening
- Dip switch 6 n/a